

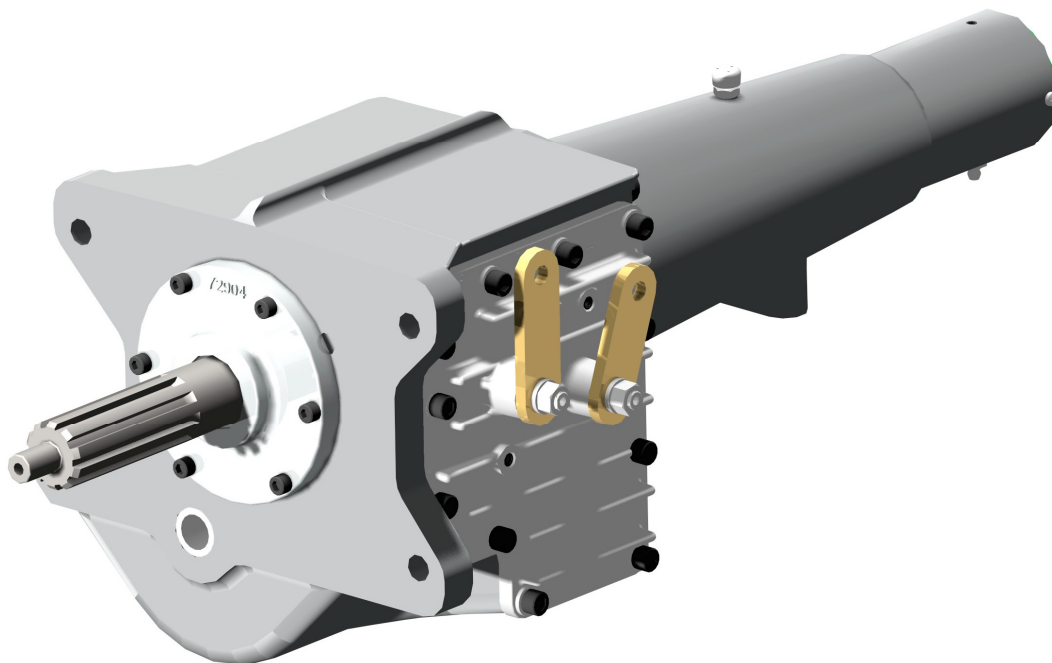

70001 and 70010 Clutch Rebuild Instructions



Brinn, Incorporated
1615 Tech Drive
Bay City, MI 48706
Telephone 989.686.8920
Fax 989.686.6520
www.brinninc.com

Notice

Use these instructions if you only want to service the clutch assembly to replace the clutch discs.

Read *Rebuild Instructions for 70001 and 70010 Transmission* if you want to service the complete transmission and rebuild kit 70041 was purchased.

Recommended Tools for Replacing the Clutch Discs

Allen wrenches

Large flat blade screwdriver

Torque wrench

Silicone sealant

Light grease

Parts washer

Clutch assembly wire (Brinn part number 70046) or see Figure 3 pg. 12

Feeler gauges

Disassembly

1. Disconnect all plumbing connected to the transmission and remove the transmission from the vehicle.
2. Before disassembly, inspect the case and output housing for cracks. The area where cracking is most likely to occur is at the ribs of the case and around the output housing bolts. Inspect the input shaft for indications of damage. Damage to the output housing oil seal and bushing can indicate problems inside the transmission.
3. Drain all fluids from the transmission by removing the fill and drain plugs (71041 & 71059).
4. Remove the side cover socket head cap screws (71001) and lock washers (71043).
5. Remove the side cover (72001).
6. Remove the six socket head cap screws (71009) passing through the front retainer (72004).
7. Remove the front retainer.
8. Spin the input shaft (74020) and look for broken or missing teeth on the gears.
9. Remove the input shaft.
10. Check the condition of the input shaft bushing (71012). The bushing should be replaced if it is damaged.
11. Remove the synchronizer (74021).
12. Remove the three piston cap socket head cap screws (71034).
13. Remove the piston cap (73013)
14. Remove the three clutch actuator pins (71030).
15. Remove the four output housing bolts (71042) and three lock washers (71061).
16. Use a flat blade screwdriver to pry the output housing from the transmission case (72002 or 72020).
17. Use a large flat blade screwdriver to compress the clutch by placing the blade between the inner rear face of the transmission case and the intermediate shaft (74008) and then using a prying motion.
18. Place the clutch assembly wire over the clutch housing and driven gear – input mesh. See Figures 1 and 2.
19. Remove the intermediate shaft retainer (73014) by pushing on the counter shaft pin end that is closest to the front of the transmission.

20. Remove the counter shaft pin (73010) from the transmission case and check for signs of wear and damage.
Replace the counter shaft pin if there are grooves in the outer diameter of the pin.
21. Remove the clutch assembly through the hole normally occupied by the output housing.
22. Remove the clutch assembly wire from the clutch assembly.
23. Separate all bearings and thrust washers and look for signs of damage, such as missing needle rollers or cracks in the thrust washers.
24. Look for cracks on the large thrust washer (73009). Replace the thrust washer if there is damage.
25. Remove the forward clutch ring (73007) from the driven gear – input mesh (74002).
26. Remove and inspect the large oring (71063) for damage. Replace the oring if there is damage.
27. Inspect the thrust washers (71032) in the clutch drum for cracks. Replace the thrust washers if there is damage.
28. Separate the metallic friction discs (71018) from the steel clutch pressure discs (71017).
29. Measure the thickness of the metallic friction discs and steel clutch pressure disks with calipers or micrometers. Replace any disc that is thinner than 0.075”.
30. Measure the thickness of the rear clutch disc (71021). Replace the disc if it is thinner than 0.178”.
31. Measure the thickness of the forward clutch ring (73007). Replace the ring if it is thinner than 0.210”.
Remove all burrs and raised edges before reassembly.
32. Use a parts washer to clean all of the metal parts shown in Figures 1 and 2. All dried silicone must be removed from the output housing, main case, piston cap, intermediate shaft retainer, and front retainer.
Replace any needle roller bearings if the rollers fall out of the cages during cleaning.
33. Use pressurized air to remove excess parts washer fluid. Do **NOT** allow any of the bearing components to spin while removing excess parts washer fluid. Damage and/or injury could occur.
34. Use a wire brush to remove any silicone not removed in the parts washer.
35. Visually inspect the synchronizer after cleaning. Visually check that the lugs on the synchronizer are back tapered. Replace the synchronizer if the lugs are not back tapered, have rounded corners, or if there are problems keeping the transmission in gear.

36. Reinspect the case and output housing after washing

Reassembly

1. Thread the fill and drain plugs (71041 & 71059) into the transmission case. Do not over tighten the plugs as severe damage to the transmission case could result. The drain plug has a magnet on the end of it and it is threaded into the hole that is closest to the bottom of the transmission case.
2. Pack all of the bearings with grease.
3. Assemble the clutch using Figure 1 or 2 as reference. There are two models of the 70001 and 70010 transmissions. The newer models do **NOT** use a retaining ring to locate the first driver gear (74012). The older models use a retaining ring (71047) to locate the first driver gear (74012). Figure 1 should be used if a retaining ring is **NOT** used to locate the first driver gear (74012). Figure 2 should be used if a retaining ring (71047) is used to locate the first driver gear (74012). The clutch requires six metallic friction discs (71018) and five steel clutch pressure discs (71017) if the retaining ring is **NOT** used. The clutch requires six metallic friction discs (71018) and six steel clutch pressure discs (71017) if the retaining ring (71047) is used. Apply one of the recommended fluids to each metallic friction disc (71018) before it is installed.
4. Compress the clutch assembly and place the clutch assembly wire over the clutch housing and the driven gear – input mesh. See Figures 1 and 2.
5. Position the transmission case on its front face.
6. Pass the clutch assembly through the large hole in the rear of the transmission case.
7. Place one thrust washer (71025) onto the intermediate shaft.
8. Place one needle thrust bearing (71026) onto the thrust washer (71025).
9. Place one thrust washer (71025) onto the thrust bearing (71026). There should now be one thrust bearing (71026) between two thrust washers (71025).
10. Align the clutch assembly, thrust washers, and thrust bearing with the counter shaft pin hole in the transmission case.
11. Pass the counter shaft pin (73010) through the center of the thrust washers, thrust bearing, and clutch assembly, but do not push the counter shaft pin through the front of the transmission case.

12. Now place the transmission case onto its back face while preventing the counter shaft pin from falling out of the transmission case.
13. Apply grease to one flat face of the intermediate shaft thrust race (73009).
14. Place the greased surface of the intermediate shaft thrust race against the top surface of the driven gear - input mesh (74002).
15. Place a needle thrust bearing (71026) onto the intermediate shaft thrust race (73009). Position the needle thrust bearing on the intermediate shaft thrust race so that the needle thrust bearing is just visible through the counter shaft pin hole in the transmission case.
16. Place a thrust washer (71013) onto the needle thrust bearing (71026).
17. Align the intermediate shaft thrust race, needle thrust bearing, and thrust washer with the counter shaft pin hole in the transmission case.
18. Now push the counter shaft pin through the front of the main case. Verify that there is a thrust washer touching the transmission case at each end of the clutch assembly. Verify that the counter shaft pin passes through all of the components shown in Figures 1 and 2.
19. **Remove the clutch assembly wire from the clutch assembly.**
20. Verify the operation of the clutch by compressing it with a large flat blade screwdriver. The clutch should disengage when the screwdriver is removed. Do not proceed until the clutch operates correctly and opens completely when the screwdriver is removed. There should be 0.080" to 0.100" of clutch movement. Check this with feeler gauges.
21. Apply a thin layer of silicone to the main case around the output housing opening and around the openings for the clutch actuator pins and piston cap screws. Do not allow silicone to enter the holes for the clutch actuator pins.
22. Slide the output housing into the main case. Mesh the gears on the output shaft with the gears on the intermediate shaft as the output housing is installed.

23. Install the four 7/16-14 x 1.50" output housing bolts (71042) and three lock washers (71061). A lock washer is not used on the bolt closest to the piston cap. Apply anti-seize to the bolts if the transmission case is magnesium. Torque the bolts to 40-45 ft-lbs.
24. Place the intermediate shaft retainer (73014) onto the transmission case.
25. Install the three clutch actuator pins (71030).
26. Check the clutch movement again by pushing on the exposed ends of the clutch actuator pins. There should be 0.080" to 0.100" of free play.
27. Apply silicone to the face of the piston cap (73013).
28. Attach the piston cap to the main case with three 1/4-20 x 2.25" socket head cap screws (71034). Position the piston cap so that the bleeder is closest to the output housing bolt that does not use a lock washer. Apply anti-seize to the screws if the transmission case is magnesium. Torque the screws to 60 in-lbs (5 ft-lbs).
29. Lay the transmission on its side with the side cover cutout facing up.
30. Apply a light coating of a recommended fluid to the output shaft spline inside the transmission case.
31. Install the synchronizer (74021). The side with six lugs points towards the output housing.
32. Verify that the synchronizer slides freely and does not bind.
33. Grease the inner diameter of the input shaft and insert the input shaft bushing (71012) into the input shaft.
34. Grease the end of the output shaft.
35. Slide the input shaft assembly into the main case.
36. Rotate the input shaft and check for any problems such as binding or excessive noise.
37. Slide the reverse idler gear until it engages and rotate the output shaft to check for problems. The output shaft should spin. Any binding of the transmission gears indicates a problem.
38. Disengage the reverse idler gear.
39. Slide the synchronizer until it engages with the input shaft and rotate the input shaft. Check for problems.
40. Grease the groove in the synchronizer while the input shaft is spinning.
41. Slide the synchronizer into the neutral position.
42. Apply grease to the front retainer oil seal.

43. Apply silicone to the back face of the front retainer.
44. Slide the front retainer over the input shaft. The oil return galley in the front retainer should be positioned towards the bottom of the transmission. The front retainer bolt pattern is not symmetric to prevent incorrect installation.
45. Thread the six 1/4-20 x 1.00" socket head cap screws (71009) through the front retainer and into the transmission case. Apply anti-seize to the screws if the transmission case is magnesium. Torque the screws to 60 in-lbs (5 ft-lbs) in a criss cross pattern.
46. Slide a yoke into the output housing. The yoke should slide and spin freely. The bushing set screw may need to be adjusted if the yoke binds.
47. Apply silicone to the surface of the side cover that mates to the transmission case.
48. Move the synchronizer and the reverse idler gear to their neutral positions.
49. Move both shift levers on the side cover to their neutral positions.
50. Reinstall the side cover. Be sure that the shift forks engage with the synchronizer and the reverse idler gear.
51. Attach the side cover to the transmission case using eleven 5/16-18 x 0.87" socket head cap screws (71001) and lock washers (71043). Apply anti-seize to the screws if the transmission case is magnesium. Torque the bolts to 200 in-lbs (17 ft-lbs).
52. Shift the transmission to low, high, and then reverse to verify that the transmission is functioning correctly.
53. Refill the transmission with the recommended fluid after installing onto the vehicle.

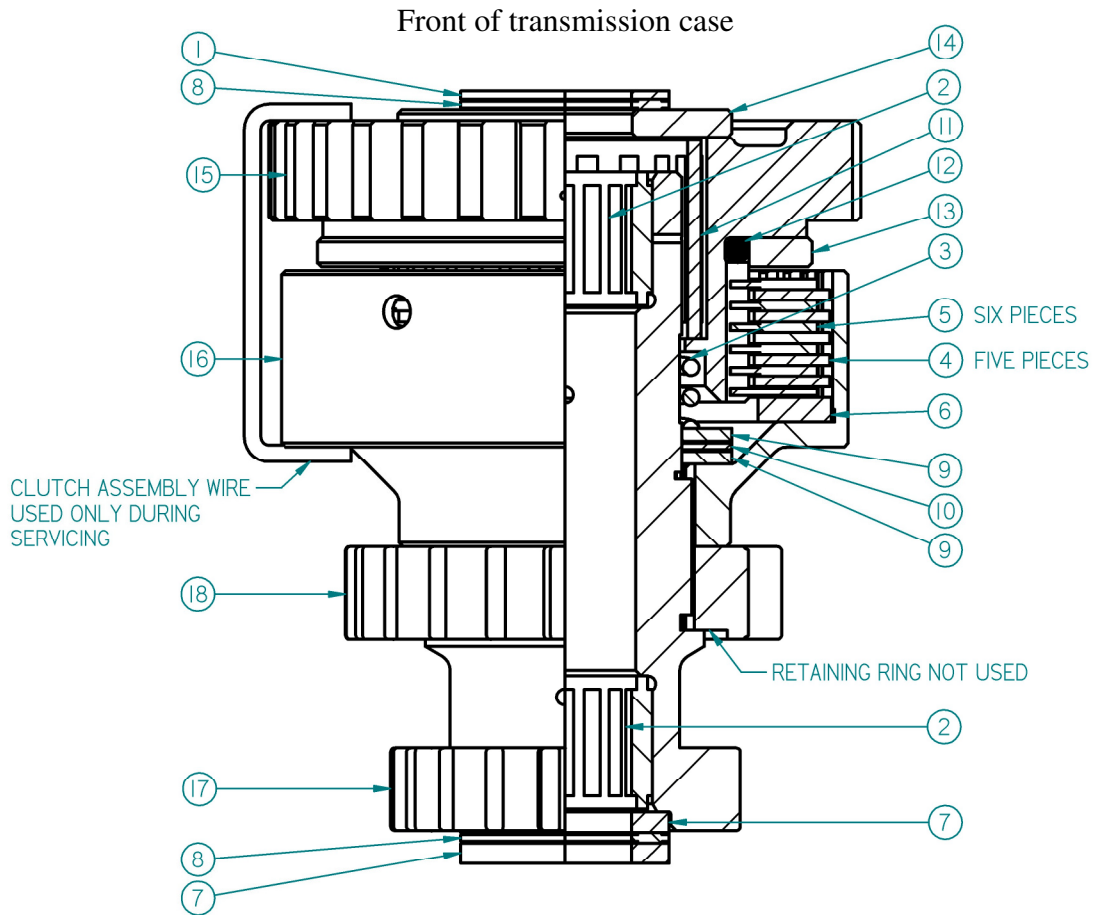

Item Number	Part Number	Description
1	71013	TORRINGTON THRUST WASHER #TRB-1625 (.060-.063 THICK)
2	71015	INA UNIT CAGE #C-162116
3	71016	SPRING - CLUTCH RELEASE
4	71017	STEEL CLUTCH PRESSURE DISC
5	71018	METALLIC FRICTION DISC
6	71021	REAR CLUTCH DISK (.183 THICK)
7	71025	TORRINGTON THRUST WASHER #TRE-1625 (.154-.157 THICK)
8	71026	TORRINGTON NEEDLE THRUST BEARING #NTA-1625
9	71032	TORRINGTON THRUST WASHER #TRC-2840 (.092-.095 THICK)
10	71033	TORRINGTON NEEDLE THRUST BEARING #NTA-2840
11	71049	INA UNIT CAGE #C-283424
12	71063	ORING 70 DUROMETER NITRILE
13	73007	FORWARD CLUTCH RING
14	73009	THRUST RACE INTERMEDIATE SHAFT
15	74002	DRIVEN GEAR - INPUT MESH
16	74006	CLUTCH HOUSING
17	74008	INTERMEDIATE SHAFT
18	74012	GEAR - FIRST DRIVER

Figure 1. Clutch assembly without retaining ring (71047).

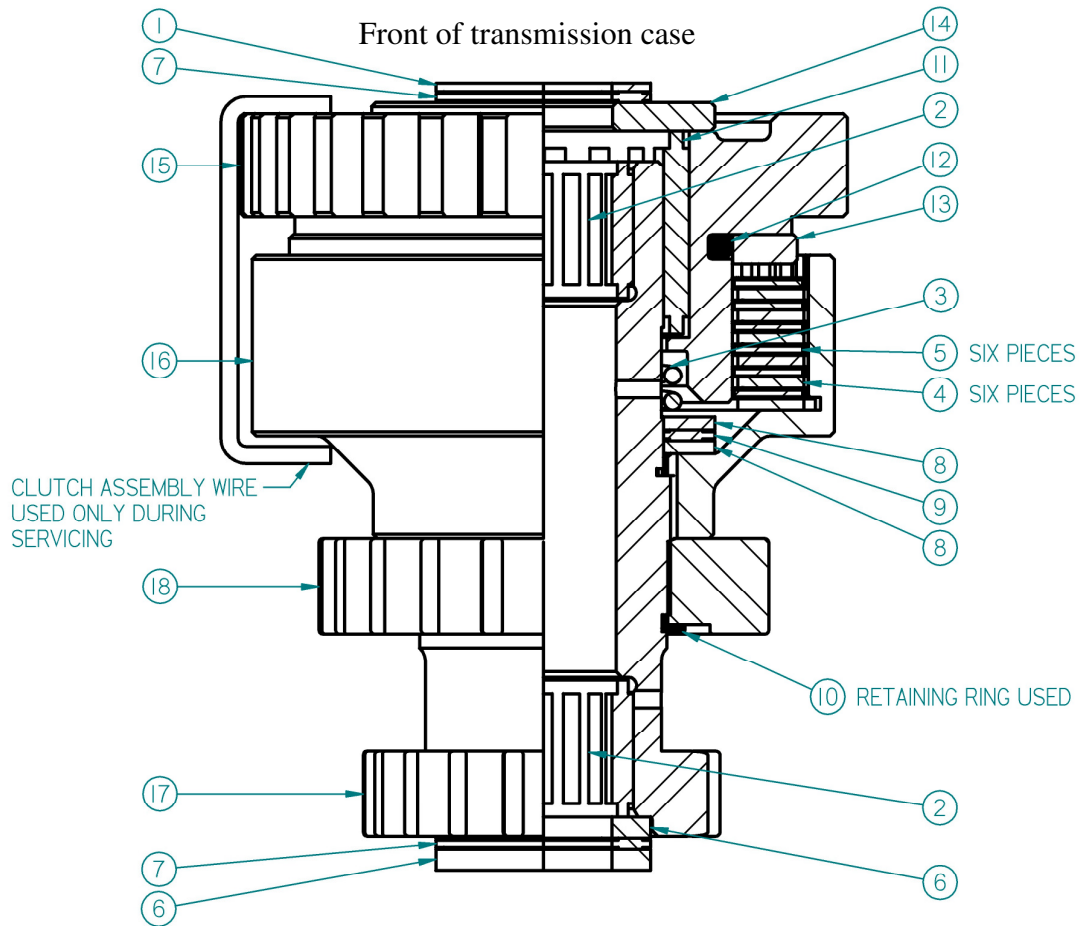

Item Number	Part Number	Description
1	71013	TORRINGTON THRUST WASHER #TRB-1625 (.060-.063 THICK)
2	71015	INA UNIT CAGE #C-162116
3	71016	SPRING - CLUTCH RELEASE
4	71017	STEEL CLUTCH PRESSURE DISC
5	71018	METALLIC FRICTION DISC
6	71025	TORRINGTON THRUST WASHER #TRE-1625 (.154-.157 THICK)
7	71026	TORRINGTON NEEDLE THRUST BEARING #NTA-1625
8	71032	TORRINGTON THRUST WASHER #TRC-2840 (.092-.095 THICK)
9	71033	TORRINGTON NEEDLE THRUST BEARING #NTA-2840
10	71047	SMALLEY RETAINING RING WS-187
11	71049	INA UNIT CAGE #C-283424
12	71063	ORING 70 DUROMETER NITRILE
13	73007	FORWARD CLUTCH RING
14	73009	THRUST RACE INTERMEDIATE SHAFT
15	74002	DRIVEN GEAR - INPUT MESH
16	74006	CLUTCH HOUSING
17	74008	INTERMEDIATE SHAFT
18	74012	GEAR - FIRST DRIVER

Figure 2. Clutch assembly with retaining ring (71047).



Figure 3. Clutch assembly wire dimensions. Not to scale.